

UNIVERSAL DIN RAIL TRANSMITTER

SEM1610

- SIMPLE CONFIGURATION VIA USB PORT
- UNIVERSAL PT100, THERMOCOUPLE, mV, mA Input
- ISOLATED INPUT
- PUSH BUTTON USER TRIM
- (4 to 20) mA TWO WIRE OUTPUT



INTRODUCTION

The SEM1610 is the next generation DIN rail mounted temperature transmitter from Status Instruments. It has been designed to accept most common process and temperature sensor inputs and provide the user with a standard two wire (4 to 20) mA output signal. Galvanic isolation is provided between input and output and all temperature ranges are linear to temperature.

Designed for ease of use, our latest USB interface is fitted for quick and easy configuration. Just connect a standard USB cable between the SEM1610 and your PC. Using our free configuration software, your PC will automatically upload the existing configuration data and guide you through any changes you wish to make. To further help save time, the SEM1610 does not need to be wired to a power supply during the configuration process, it is powered via the USB interface from your PC. The following parameters are configurable :-

INPUT TYPE	LOW RANGE	HIGH RANGE	UNITS	BURNOUT	USER TRIM
PT100	Input @ 4 mA	Input @ 20 mA	°F, °C	Up/Scale Down/Scale	On , Off
T/C K, J, E, N, T, R, S			°F, °C	Up/Scale Down/Scale	
mV			mV	Up/Scale Down/Scale	
mA			mA		

The SEM1610 is also provided with user push button adjustment, allowing input adjustments at both 4 mA and 20 mA. The user adjust function can be locked during configuration if not required. The state led indicates out of range input during normal operation, during user adjust it is also used to indicate the stage of adjustment.

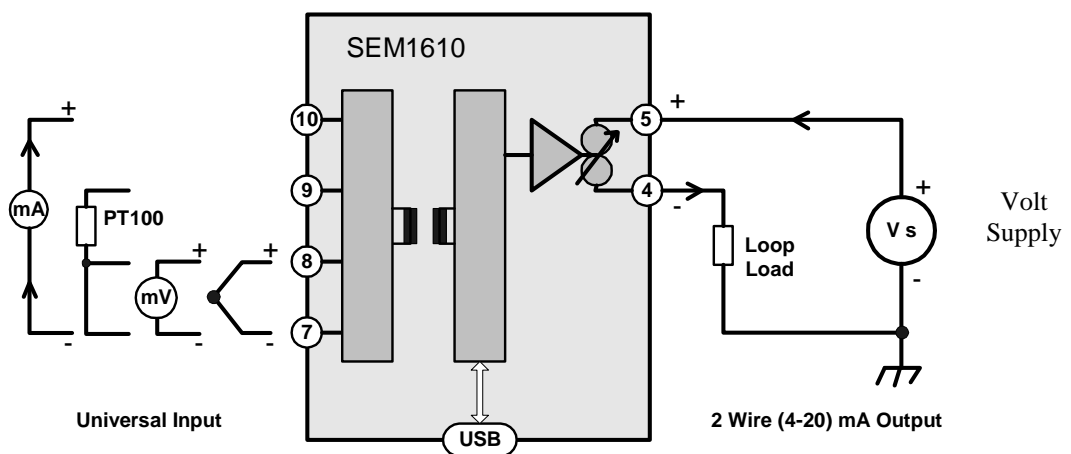

UNIVERSAL DIN RAIL TRANSMITTER

SPECIFICATION @ 20 °C

INPUTS

INPUT	RANGE	ACCURACY (Note 1)	STABILITY (Note 7)	O/C	CJ (Note 3)	Sensor excitation (Note 4)	IMPEDANCE
K	(-200 to 1370) °C	0.1 % of FSR ±0.5 °C (type T 0.2 % FSR. ± 0.5 °C)	± 0.01 % of FSR / °C	Yes	Yes	-	1 MΩ (Note 5)
J	(-100 to 1200) °C						
E	(-100 to 1000) °C						
N	(-180 to 1300) °C						
T	(-100 to 400) °C						
R	(-10 to 1760) °C	± 0.5 °C ±0.1 % of FSR (Note 2)					
S	(-10 to 1760) °C	± 0.5 °C ±0.1 % of FSR (Note 2)					
mV	(-40 to 75) mV	± 0.04 mV			-		
P	(-200 to 850) °C	± 0.1 °C / ±0.05 % of rdg	± 0.005 % of FSR / °C		-	<450 uA	-
mA	(-10 to 25) mA (4 to 20) mA Capability	± 0.008 mA	± 0.01 % of FSR / °C	-	-	-	2.7 R (Note 6)

Key Rdg = Reading ; FSR = Full Scale Range ; O/C = programmable open circuit sensor detect; CJ = Cold junction error

Notes

1. Accuracy for PT100 and T/C do not include sensor and cold junction errors.
2. Only over the range (800 to 1600) °C
3. Cold junction range (-20 to 70) °C, Accuracy ± 0.5 °C, Tracking ± 0.05 °C
4. PT100 input Maximum lead resistance 20 R, Lead effect 0.015 °C / Ω.
5. Impedance – not including 0.2 uA open circuit detect bias current effect.
6. Maximum current over load ± 100 mA.
7. Ambient (-10 to 50) °C

OUTPUT

Type

Two wire current sink; signal range (4 to 20) mA; full range (3.8 to 24) mA

Supply

(11 to 30) V dc, 24 V nominal giving Max loop load of 600 R @ 24 V

Response time

< 500 ms to reach 95 % of final value ; Start up time < 3 s

Calibration Accuracy

± 5 uA

Loop Effects

Loop ripple 0.03 % of FSR; Supply sensitivity 0.05 uA / °C ; supply ripple rejection < ± 5 uA error @ 1 V rms 50 Hz ripple

Protection

Reverse connection and over-voltage protection. Max over voltage current 100 mA.

User Trim

Raise and lower buttons, active for offset when output is between (3.8 to 6) mA, Span between (18 to 22) mA. Trim lock option.

Stability

± 5 uA / °C.

GENERAL

Galvanic Isolation

Input to output tested at 500 V dc. Working isolation = 48 VDC.

Ambient

operating (-20 to 70) °C (10 to 95) % RH non condensing. Storage (-40 to 85) °C

Approvals

CE tested to BS EN 61326

LED Indication (State)

OFF = OK ,

ON(RED) = Input/Output error plus trim function : refer to manual.

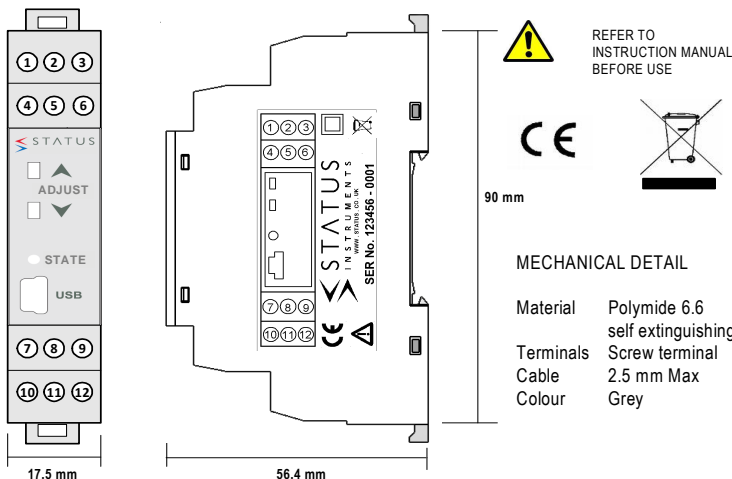

ORDER CODE : SEM1610

ASSOCIATED PRODUCTS

USB CABLE A/M TO MINI B/M
USB Link Software

ORDER CODES

48-200-0001-01
FOC @ www.status.co.uk Downloads