

#### 4. Continued

#### Re-Ranging And Calibration Procedure

Before you start you will need the following equipment and information:-

- Resistance box; accuracy  $\pm 0.01$  ohms or better to simulate Pt100
- DC milliamp meter (Digital); accuracy 0.05% on 0-20 mA range.
- Power supply; 24 VDC 30 mA min output current.
- Suitable wires together with a trim tool and the Pt100 equivalent resistance values for the range limits you require to set, i.e. the 4 mA and 20 mA calibration points.

**Step 1.** Decide on the range you require, let

$T_h$  = Required Temperature @ 20 mA Output

$T_{lo}$  = Required Temperature @ 4 mA Output

**Step 2.** Calculate SPAN

$$\text{SPAN} = T_h - T_{lo}$$

**Step 3.** Calculate TRUE-ZERO

$$\text{TRUE-ZERO} = T_{lo} - (\text{SPAN}/4)$$

**Step 4.**

Look up your SPAN and TRUE-ZERO temperature in the tables below, and note the links that need to be made. Then using a soldering iron, blob the links on the PCB mounted inside the enclosure. Ensure any non called up links, soldered for a previous range, are open circuited by removing the solder blob. Note you will need to remove the enclosure base to gain access to the links. There are eight links in total, (A,B,C,D) affect SPAN, and (W,X,Y,Z) affect TRUE-ZERO.

**Table 1 Span Links Group A, B, C + D**

SPAN °C	Solder Links
22 / 37	D
37 / 52	B,C
52 / 75	C
75 / 140	A,B
140 / 215	B
215 / 500	A

**Table 2 True Zero Links, Group W, X, Y + Z**

TRUE-ZERO °C	Solder Links
-180 / -166	W,X,Y,Z
-166 / -147	W,X,Y
-147 / -127	W,X,Z
-127 / -108	W,X
-108 / -88	W,Y,Z
-88 / -69	W,Y
-69 / -49	W,Z
-49 / -35	W
-35 / -21	X,Y,Z
-21 / -1	X,Y
-1 / 18	X,Z
18 / 38	X
38 / 57	Y,Z
57 / 77	Y
77 / 96	Z
96 / 100	-

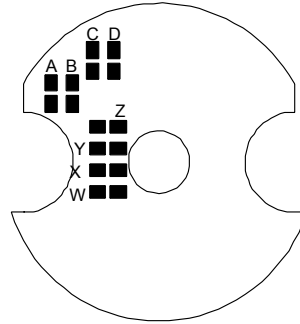

**Step 5.** Recalibrate

- Look up your SPAN & TRUE-ZERO temperature in the tables overleaf & note the links that need to be made. Using a soldering iron blob the links on the PCB. Ensure any links not called up, soldered from a previous range, are open circuited by removing the solder blob. Note you will need to remove the enclosure base to gain access to the links. There are 8 links in total, ABCD affect SPAN and WXYZ affect TRUE-ZERO.
- Set the resistance box to the equivalent sensor resistance for the temperature you require for 4mA output. Adjust the Z zero trim potentiometer for 4mA  $\pm 0.01$ mA output current.
- Set the resistance box to the equivalent sensor resistance for the temperature you require for 20mA output. Adjust the S span trim potentiometer for 20mA  $\pm 0.01$ mA output current.
- Repeat steps b & c until both points are in calibration. Note some interaction between adjustments will occur.
- Switch off power & remove wires. Mark transmitter with the new range.

**Example**

- Range 50/200 °C.
- Span = 200 - 50 = 150
- True Zero = 50 - (150/4) = 50 - 37.5 = 12.5
- Span falls in 140/215 range therefore link B is made.
- True Zero falls in -1/18 range therefore links X and Z are made.
- Check that all other links are open circuit.

## SEM104/P Pt100 Transmitter

Designed, manufactured and supported by :



Tewkesbury  
Glos. GL20 8FD, UK  
Telephone : 01684 296818  
Fax : 01684 293746  
Email:

Every effort has been taken to ensure the accuracy of this specification, however we do not accept responsibility for damage, injury, loss or expense resulting from errors and omissions, and we reserve the right of amendment without notice.

Stock code : 52-214-2010-03



## 1.0 DESCRIPTION

The device is a temperature transmitter designed to accept a standard platinum resistance sensor (Pt100 2 or 3 wire) to BS EN 60751, BS1904 or DIN 43760 and convert the temperature to industrial 4-20mA. It is housed in a purpose designed DIN standard connecting block enclosure.

The transmitters are available in 6 standard factory calibrated ranges, but the transmitter can be user re-ranged to operate over most temperature ranges encountered in both industrial and building management applications. Non standard ranges can be supplied to special order. The enclosure provides trim potentiometer access, allowing fine re-calibration adjustments to be made at both ends of the scale.

## 2.0 SPECIFICATION @ 20 °C

Input	Pt100 sensor to BS EN 60751, BS1904 or DIN 43760
Output	100 R @ 0 °C. FI = 38.5 R, 2 or 3 wire.
Loop Supply	4-20 mA Loop powered, Max 30 mA
Loop Resistance	10 to 30 VDC
Loop Protection	700R @ 24V
Loop Sensitivity	Reverse connection protected
Accuracy	10 µA/volt
Temp Stability	±0.2 °C plus ±0.2% of reading
Ambient Temp	Zero Drift Typically 0.05% full range output / °C
	Span Typically 0.002% full range output / °C
Ambient Humidity	0 to 70 °C Operating
Connection	-40 to 70 °C Storage
Cable Size	0 to 95 % (Non Condensing)
EMC Conforms to	Screw Terminal
	Recommended Max wire 2.5 sq. mm
	BS EN 50081-1
	BS EN 50082-1

## 3.0 INSTALLATION

### 3.1 Mechanical

The transmitter is mounted using two 5.5mm diameter holes, on standard 33 mm fixing centres. This transmitter has been specifically designed to be mounted inside a DIN standard probe head enclosure, which must provide adequate protection from moisture, corrosive atmosphere etc. All cable entries should be sealed using the correct size cable gland. Care must be taken when locating the transmitter to ensure the ambient temperature will remain inside the specified range of 0 to 50 °C. The diagrams show the mechanical layout and a typical application of the transmitter mounted inside a probe head enclosure, with sensor wires entering through the centre hole.

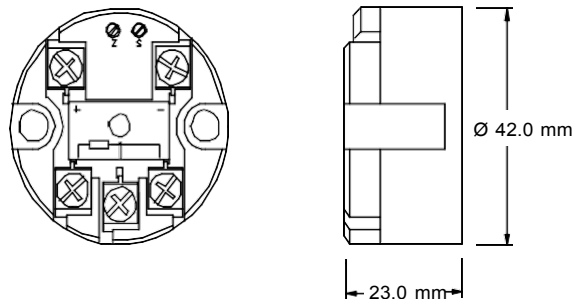

Mounting holes : 2 holes 5.5mm diameter, 33mm centres  
Centre hole sensor wire entry : 4.0mm diameter

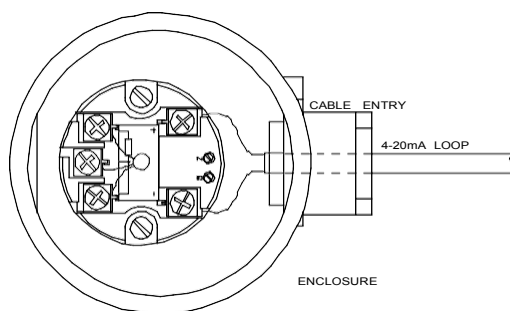

### 3.2 Electrical

Connections to the transmitter are made to the screw terminals provided on the top face. To maintain CE compliance, input wires must be less than 3 metres in length and output wiring must be screened cable, with the screen earthed at one end only. All three input wires must have the same core diameter to maintain equal lead resistance in each wire. A hole is provided through the centre of the transmitter to allow sensor wires, (entering direct from the probe assembly via a base entry), to be threaded through the transmitter body, direct to the input screw terminals. The screw terminals have been designed to allow all connection wires to enter from either an inner or outer direction.

The transmitter is protected against reverse connection by means of a series diode, therefore incorrect connection of the output wires will result in near zero current flow in the loop. Incorrect connection of the sensor wires will result in the transmitter saturating at either its low or upper limits.

The diagram shows the method of connection to provide a 4-20 mA current loop output. The Pt100 sensor shown would normally take the form of a probe assembly with a three wire output. The output loop shows a 24 VDC power supply, used to provide loop excitation, the transmitter, and a load all connected in series. The load symbol represents other equipment in the loop e.g. indicators, controllers, loggers etc. Sometimes these instruments may come with the 24V supply built in as standard, this simplifies wiring and reduces cost.

Care must be taken when designing the 4-20mA circuit to ensure that the total burden of the loop, that is the total voltage requirements of all the equipment in the loop added together, does not exceed the power supply voltage. If a number of transmitters are connected in the loop, ensure that only one instrument is tied to ground. Grounding the loop at two points will result in shorting out part of the loop and therefore any transmitters in that part of the loop will not operate.

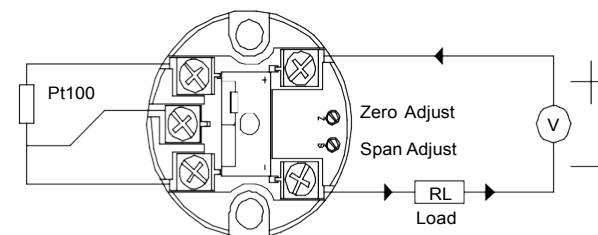

Maximum load resistor, RL, is calculated as follows :

$$RL = (v-10)/20 \times 1000$$

For 24V supply :

$$RL = (24-10)/20 \times 1000 = 700R$$

### 3.3 EMC

This transmitter conforms with EC directive BS EN 50081-1 and BS EN 50082-1 when correctly installed in a termination head providing at least IP20 protection and fitted with a sensor with less than 3 metres of cable.

### 4.0 RANGES

This transmitter is normally supplied in one of six standard ranges. Other ranges can be supplied at time of order but with the aid of suitable equipment, the user can re-range the transmitter. On board links allow the transmitter to be re-ranged to operate over most common industrial and commercial ranges. Due to the nature of this transmitter, changes in span range affect both 4 and 20 mA calibration points. Ranging the transmitter is very much simplified if calculations are based on the true zero of the transmitter, i.e. the temperature at which the output would in theory be at 0mA.

To verify that the transmitter will operate over the range you require, please follow the simple procedure listed overleaf, calculating the SPAN and TRUE-ZERO temperatures for your range. Then ensure these temperatures fall into one of the bands for SPAN and TRUE-ZERO listed in the tables overleaf. From the tables select the links you need to make, solder blob them and then follow the calibration procedure to trim the transmitter to the range you require.

- Note :** TRUE-ZERO is the temperature at which theoretical zero current would flow.